

BOLBYR®

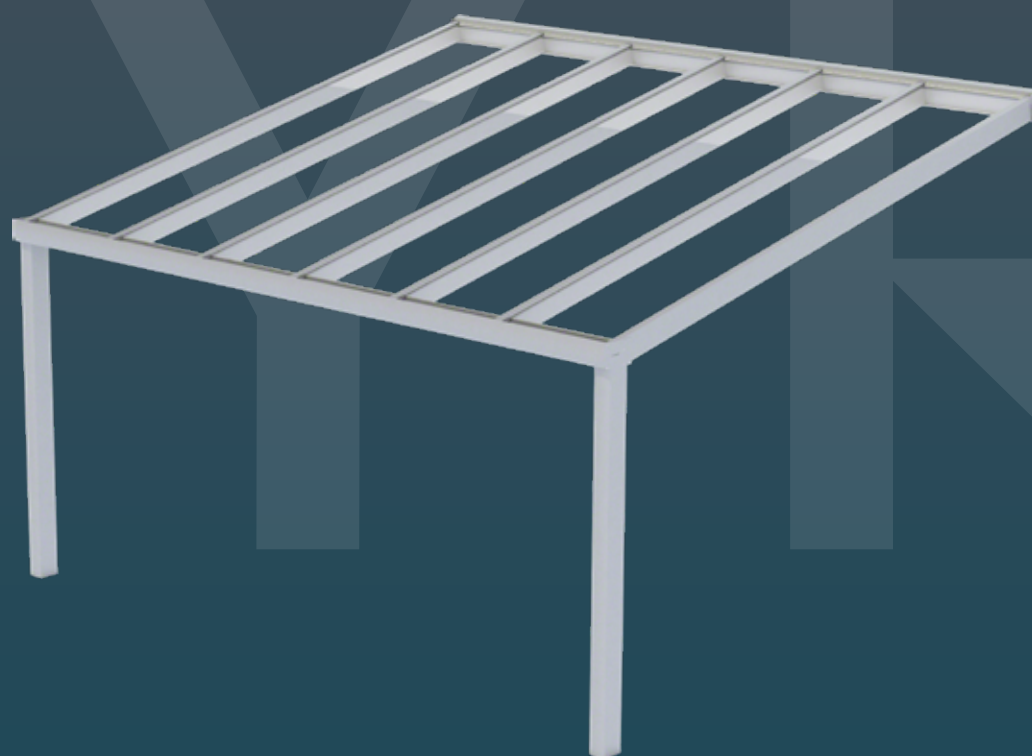

EN

NL

VERANDA | TERRASOVERKAPPING

ORION

Subject to misprints, errors and technical modifications.
Drukfouten, fouten en technische wijzigingen voorbehouden.

30514779ORION-EN-NL-240919

Contents

Inhoudsopgave

Measurements

Maatvoering 4

Technical specifications

Technische specificaties6

Shortening sizes

Afkortmaten9

Exploded view10

Bill of material

Stuklijst11

Parts list

Onderdelenlijst.....12

Additional technical information

Aanvullende technische informatie 18

Measurements

Maatvoering

Cross section | Doorsnede
 Sizes | Maten in mm

Round gutter profil Rond gootprofiel

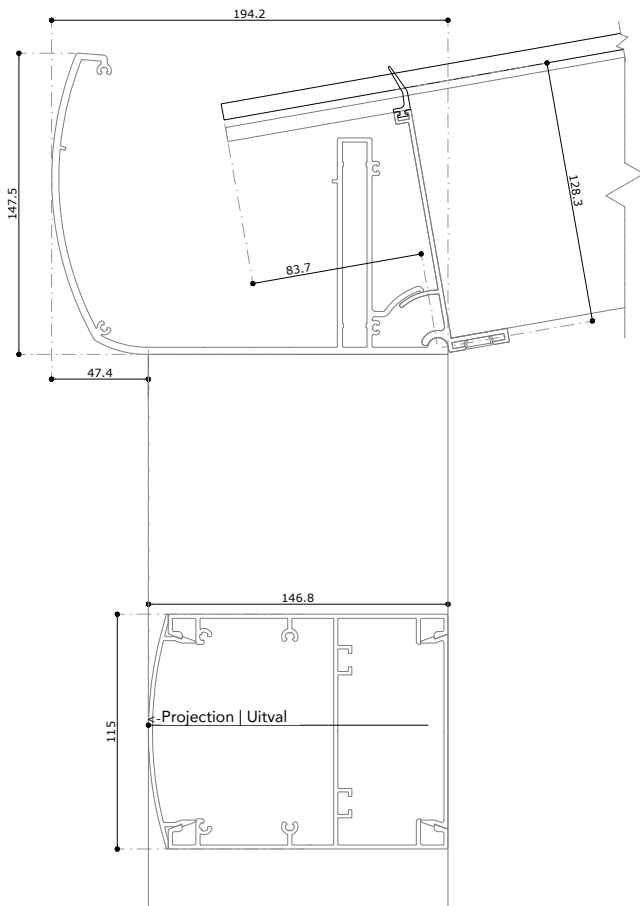

Straight gutter profile Rech gootprofiel

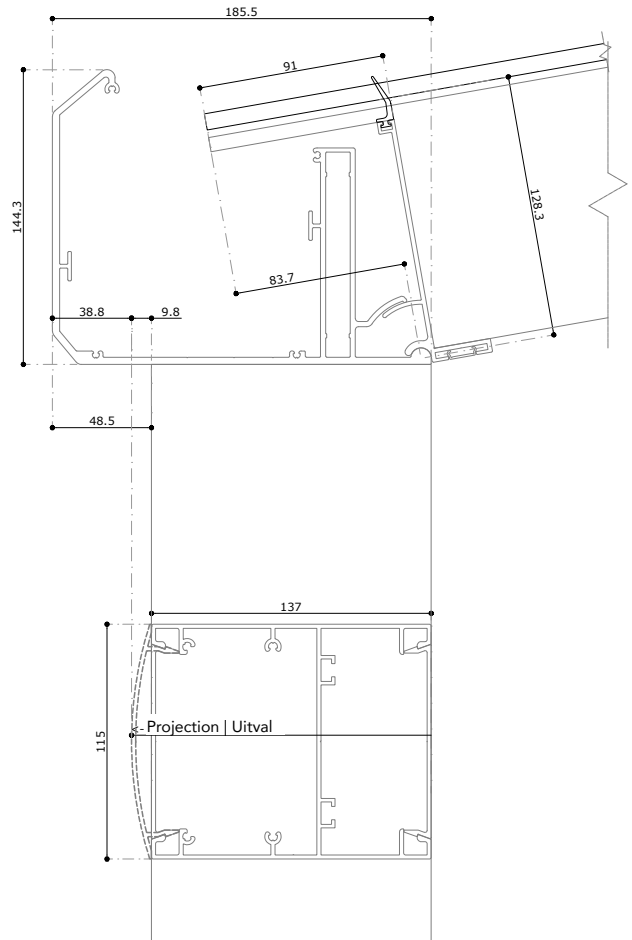

Wall profile Wandprofiel

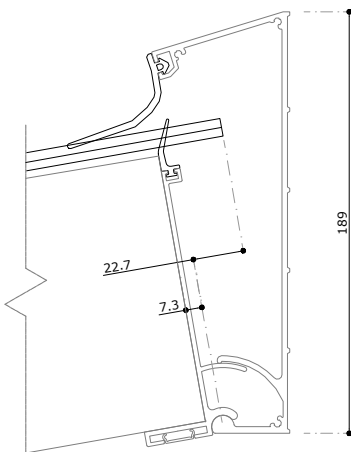

Measurements

Maatvoering

Cross section | Doorsnede
 Sizes | Maten in mm

Beam with side cover profile
Ligger met eindlijst

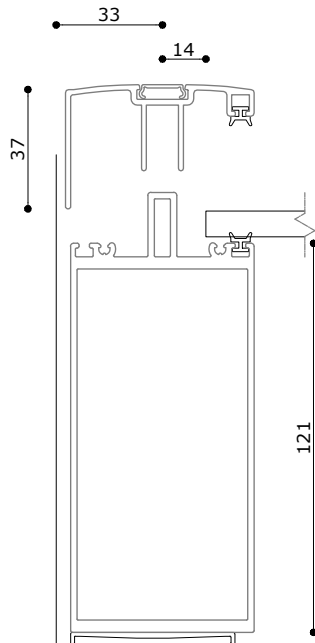



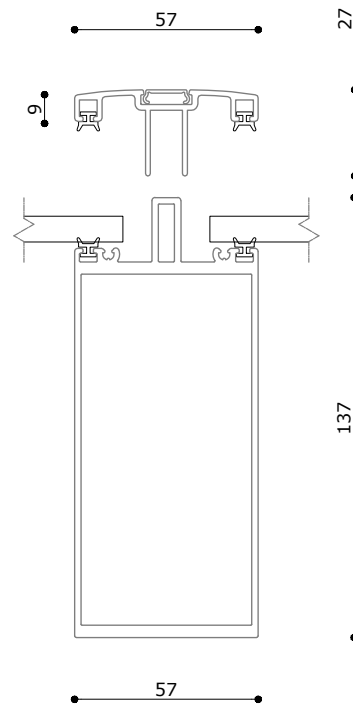

Beam with cover profile
Ligger met afdekljst



Technical specifications

Technische specificaties

Width Breedte	4000 - 5000 - 6000 - 7000 mm	
Projection Uitval	3000 - 3500 - 4000 mm	
Inclination Helling	8°	
Filling Vulling	Glass 44.2 (Not possible with polycarbonate) Glas 44.2 (Niet mogelijk met polycarbonaat)	
Available colors Beschikbare kleuren		mill finish onbewerkt
		white wit
		anthracite textured paint (VS716) antraciet structuurlak (VS716)
		black textured paint (VS905) zwart structuurlak (VS905)
Warning! Minimal color deviation reserved. Let op! Minimale kleurafwijking voorbehouden.		
CE certification CE keurmerk	CE NEN-EN 1090	

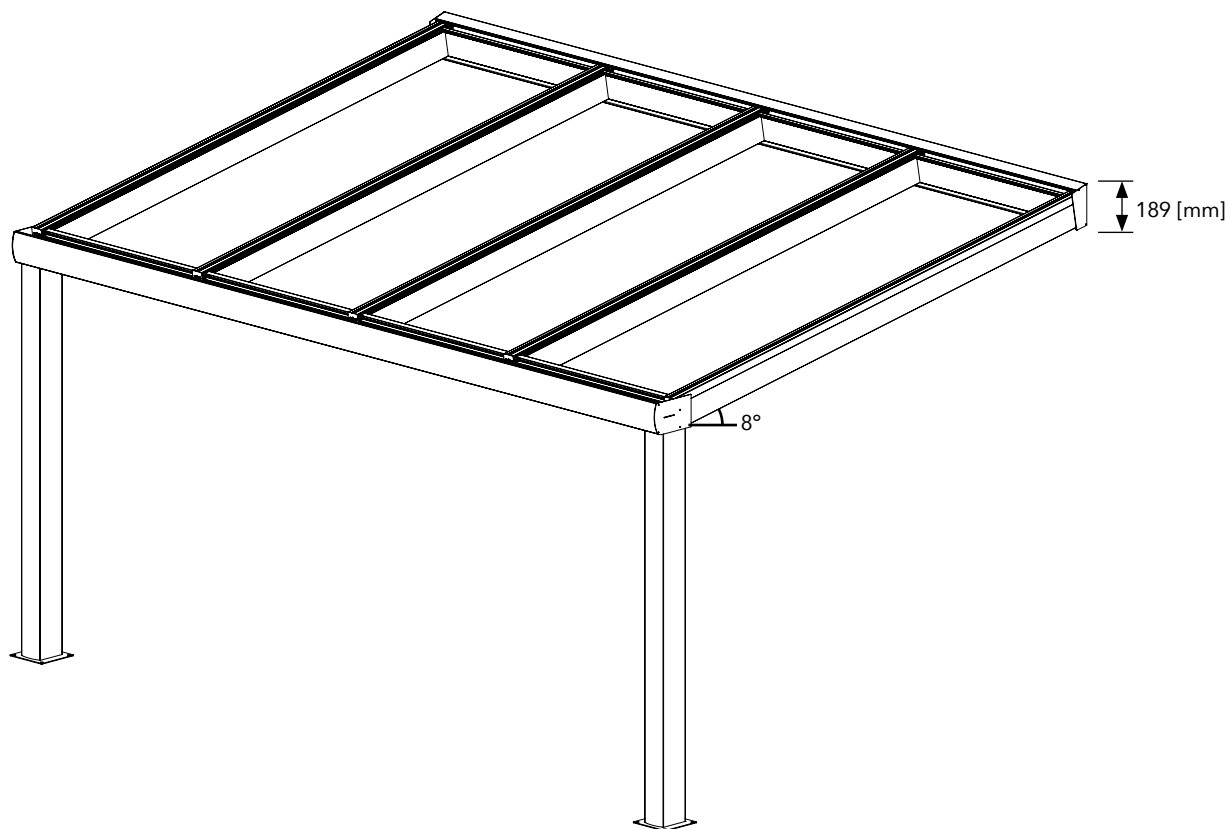

Technical specifications

Technische specificaties

B1	B2
4000	926
5000	929
6000	932
7000	933

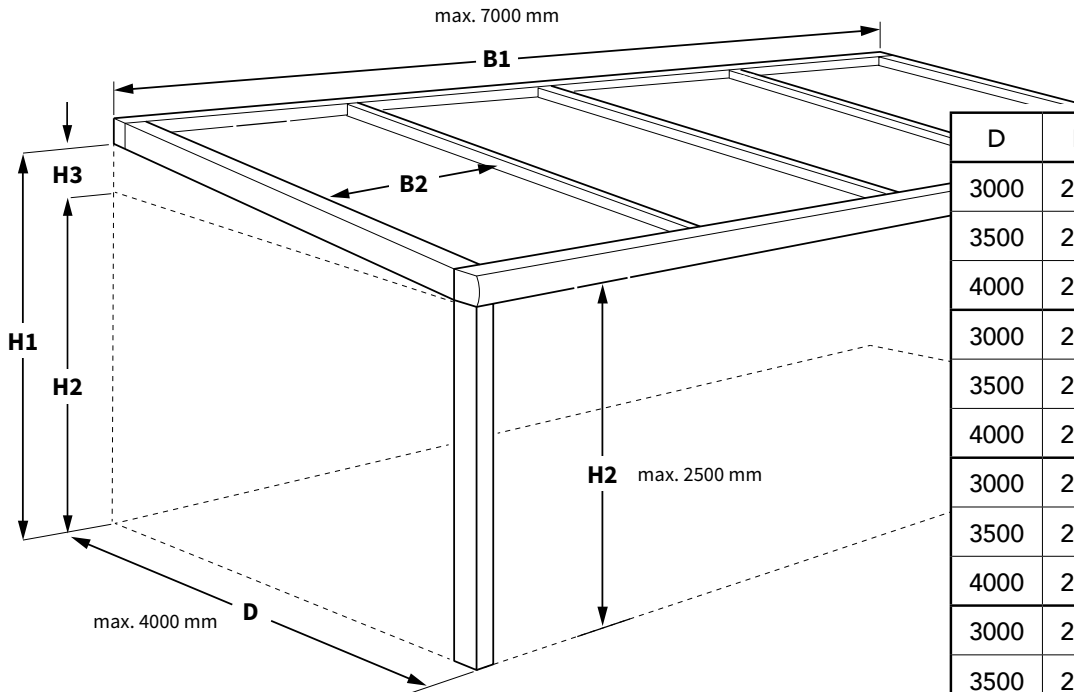

D	H2	H1	H3
3000	2100	2497	=H2+397
3500	2100	2568	=H2+468
4000	2100	2639	=H2+539
3000	2200	2597	=H2+397
3500	2200	2668	=H2+468
4000	2200	2739	=H2+539
3000	2300	2697	=H2+397
3500	2300	2768	=H2+468
4000	2300	2839	=H2+539
3000	2400	2797	=H2+397
3500	2400	2868	=H2+468
4000	2400	2939	=H2+539
3000	2500	2897	=H2+397
3500	2500	2968	=H2+468
4000	2500	3039	=H2+539

B = width | breedte
H = height | hoogte
D = projection | uitval

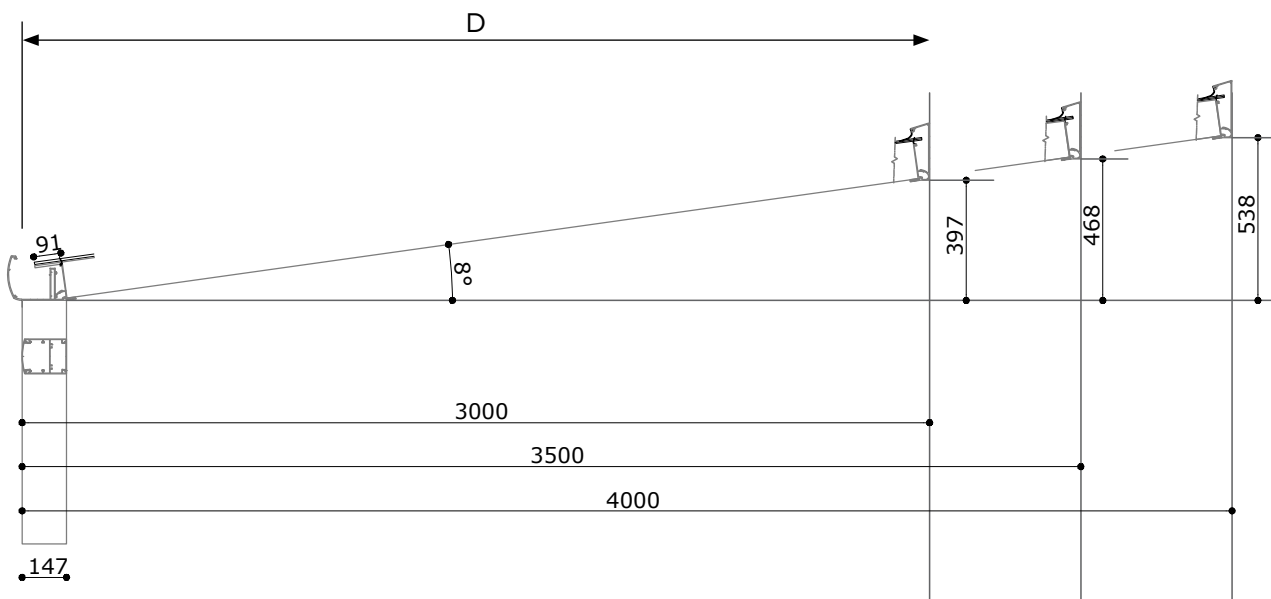

Technical specifications







Technische specificaties

STANDARD SIZES - Number of posts and fields STANDAARD MATEN - Aantal staanders en velden

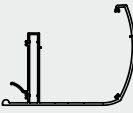
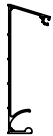
Projection Uitval [mm]	Width Breedte [mm]			
	4000	5000	6000	7000
3000				
3500				
4000				
	2 posts staanders	2 posts staanders	3 posts staanders	3 posts staanders
fields velden	4	5	6	7

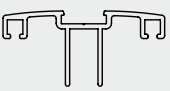
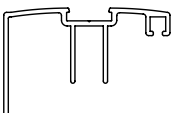
Shortening sizes

Afkortmaten

Part	Onderdeel		
1		Gutter profile Gootprofiel	- 5 mm
2		Wall profile Muurprofiel	- 5 mm
3		Hinge profile Scharnierprofiel	- 9 mm
4		Beam Ligger	depends on inclination afhankelijk van de helling
5		Cover profile Afdeklijst	depends on inclination afhankelijk van de helling
6		Side cover profile beam Eindlijst ligger	depends on inclination afhankelijk van de helling
7a		Click profile beam Klikprofiel ligger	depends on inclination afhankelijk van de helling
7b		Click profile gutter Klikprofiel goot	- 9 mm
8		Rubber for wall profile Rubberafdichting voor muurprofiel	- 5 mm
16		Condensate profile Condensprofiel polycarbonaat	- 31 mm from sheet size van plaatmaat

Exploded view

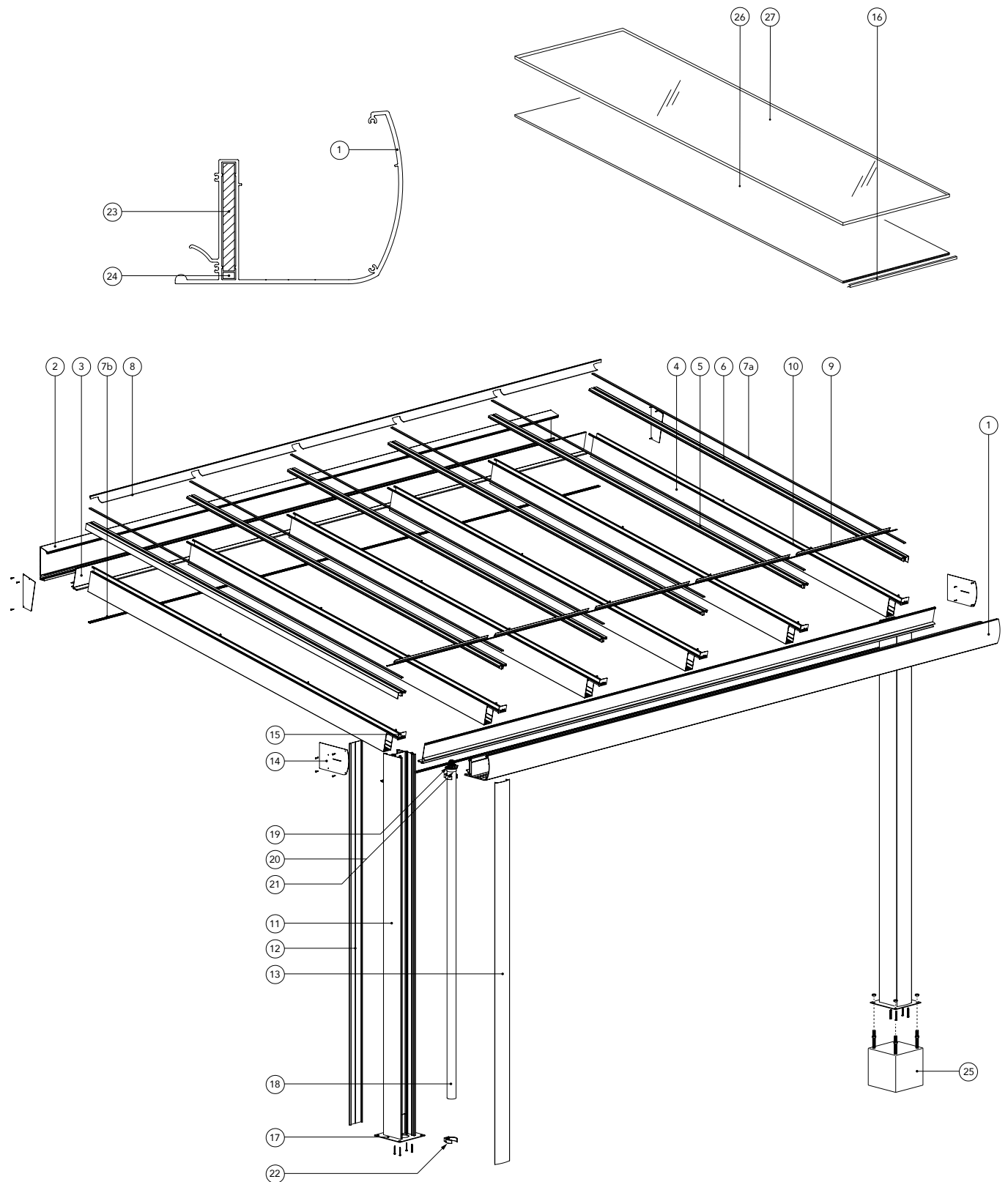



Bill of material

Stuklijst

Item Onderdeel	Description Omschrijving	Quantity Hoeveelheid
1	Gutter profile Gootprofiel	1
2	Wall profile Muurprofiel	1
3	Hinge profile Scharnierprofiel	2
4	Beam Ligger	Number of fields +1 Aantal velden +1
5	Cover profile Afdekl ijst	Number of fields -1 Aantal velden -1
6	Side cover profile beam Eindlijst ligger	2
7a	Click profile beam Klikprofiel ligger	Number of fields +1 Aantal velden +1
7b	Click profile gutter Klikprofiel goot	2
8	Rubber for wall profile Rubberafdichting voor muurprofiel	1
9	Rubber for gutter profile Rubberafdichting voor gootprofiel	1
10	Co-extrusion Poly beam Co-extrusie Poly ligger	Number of fields x4 Aantal velden x4
11	Post Staander	Number of posts Aantal staanders
12	Post click profile flat Staander klikprofiel recht/vlak	Number of posts Aantal staanders
13	Post click profile round Staander klikprofiel rond	Number of posts Aantal staanders
14	Side plates set Eindkappen set	1
15	End cap beam Eindplaat ligger	Number of fields +1 Aantal velden +1
16	Condensate profile Condensprofiel polycarbonaat	Number of fields Aantal velden
17	Foot Montagevoet	Number of posts Aantal staanders
18	Drain Afvoerbuis - Ø50 mm	1
19	Leave guard Bladvanger - Ø50 mm	1
20	Drop outlet Uitloop PVC (tule) - Ø50 mm	1
21	Nut for drop outlet Moer voor Uitloop - Ø50 mm	1
22	Pipe bracket Klembeugel - Ø50 mm	1
23	Gutter reinforcement Versterking goot - 90x10 mm	See pricelist Zie prijslijst
24	Stuffpieces for reinforcement gutter Opvulstuk voor versterking goot - 5x10 mm	See pricelist Zie prijslijst
25	Concrete block Betonpoer	Number of posts Aantal staanders
26	Polycarbonate sheet Polycarbonaat plaat	Number of fields Aantal velden
27	Glass Glas	Number of fields Aantal velden

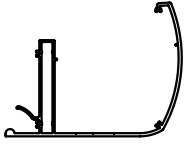
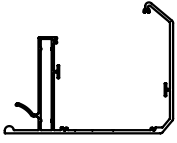

Parts list

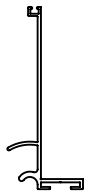
Onderdelenlijst

Part Onderdeel	Part No. Art.nr	Description Omschrijving	Length in m ¹ Unit
LENGTHS LENGTES			
1a 	Gutter profile round Gootprofiel rond		
	ART-040371	white wit	4 m ¹
	ART-024067	anthracite textured paint antraciet structuurlak (VS716)	
	ART-044413	black textured paint zwart structuurlak (VS905)	
	ART-024072	mill finish onbewerkt	7 m ¹
	ART-024073	white wit	
	ART-024075	anthracite textured paint antraciet structuurlak (VS716)	
ART-044414	black textured paint zwart structuurlak (VS905)		
1b 	Gutter profile straight Gootprofiel recht		
	ART-040376	anthracite textured paint antraciet structuurlak (VS716)	4 m ¹
	ART-044411	black textured paint zwart structuurlak (VS905)	
	ART-024083	mill finish onbewerkt	7 m ¹
	ART-024084	white wit	
	ART-024086	anthracite textured paint antraciet structuurlak (VS716)	
	ART-044412	black textured paint zwart structuurlak (VS905)	
2 	Wall profile Muurprofiel		
	ART-040373	white wit	4 m ¹
	ART-040377	anthracite textured paint antraciet structuurlak (VS716)	
	ART-044419	black textured paint zwart structuurlak (VS905)	
	ART-024005	mill finish onbewerkt	7 m ¹
	ART-024006	white wit	
	ART-024008	anthracite textured paint antraciet structuurlak (VS716)	
ART-044420	black textured paint zwart structuurlak (VS905)		
3 	Hinge profile Scharnierprofiel		
	ART-040374	white wit	4 m ¹
	ART-040378	anthracite textured paint antraciet structuurlak (VS716)	
	ART-044421	black textured paint zwart structuurlak (VS905)	
	ART-044422	black textured paint zwart structuurlak (VS905)	5 m ¹
	ART-024015	anthracite textured paint antraciet structuurlak (VS716)	6 m ¹
	ART-044423	black textured paint zwart structuurlak (VS905)	
	ART-024016	mill finish onbewerkt	7 m ¹
	ART-024017	white wit	
	ART-024019	anthracite textured paint antraciet structuurlak (VS716)	
ART-044424	black textured paint zwart structuurlak (VS905)		



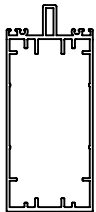
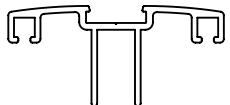
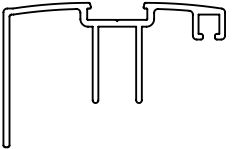
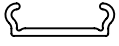
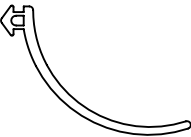

Parts list

Onderdelenlijst

Part Onderdeel	Part No. Art.nr	Description Omschrijving	Length in m ¹ Unit
4 	Beam Ligger		
	ART-024029	mill finish onbewerkt	4 m ¹
	ART-024032	anthracite textured paint antraciet structuurlak (VS716)	
	ART-044416	black textured paint zwart structuurlak (VS905)	
	ART-024033	mill finish onbewerkt	6 m ¹
	ART-024036	anthracite textured paint antraciet structuurlak (VS716)	
	ART-044417	black textured paint zwart structuurlak (VS905)	
	ART-024037	mill finish onbewerkt	7 m ¹
	ART-024038	white wit	
ART-024040	anthracite textured paint antraciet structuurlak (VS716)		
ART-044418	black textured paint zwart structuurlak (VS905)		
5 	Cover profile Afdeklijst		
	ART-024056	anthracite textured paint antraciet structuurlak (VS716)	4 m ¹
	ART-024061	mill finish onbewerkt	7 m ¹
	ART-024062	white wit	
	ART-024064	anthracite textured paint antraciet structuurlak (VS716)	
ART-044407	black textured paint zwart structuurlak (VS905)		
6 	Side cover profile beam Eindlijst ligger		
	ART-024042	white wit	4 m ¹
	ART-024049	mill finish onbewerkt	7 m ¹
	ART-024050	white wit	
	ART-024052	anthracite textured paint antraciet structuurlak (VS716)	
ART-044410	black textured paint zwart structuurlak (VS905)		
7a 7b 	Click profile beam Klikprofiel ligger		
Click profile gutter Klikprofiel goot			
ART-024024	mill finish onbewerkt	7 m ¹	
ART-024025	white wit		
ART-024027	anthracite textured paint antraciet structuurlak (VS716)		
ART-044415	black textured paint zwart structuurlak (VS905)		
8 	ART-023339	Rubber for wall profile Rubberafdichting muurprofiel	per mtr
9 	ART-023442	Rubber for gutter profile Rubberafdichting voor gootprofiel	per mtr



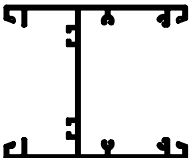

Parts list

Onderdelenlijst

Part Onderdeel	Part No. Art.nr	Description Omschrijving	Length in m ¹ Unit	
10		Co-extrusion Poly Beam Co-extrusie Poly ligger		
		ART-023340	3000 mm	
		ART-023341	3500 mm	
		ART-023342	5000 mm	
		ART-023343	6000 mm	
ART-023344	7000 mm			
16		Condensate profile Condensprofiel polycarbonaat		
		ART-023978	mill finish onbewerkt	6 m ¹
		ART-023979	white wit	
		ART-023981	anthracite textured paint antraciet structuurlak (VS716)	
ART-044392	black textured paint zwart structuurlak (VS905)			
HEIGHTS HOOGTES				
11		Post Staander		
		ART-024196	mill finish onbewerkt	5 m ¹
		ART-024197	white wit	
		ART-024199	anthracite textured paint antraciet structuurlak (VS716)	
ART-044425	black textured paint zwart structuurlak (VS905)			
12		Post click profile flat Staander klikprofiel recht/vlak		
		ART-023986	mill finish onbewerkt	5 m ¹
		ART-023987	white wit	
		ART-023989	anthracite textured paint antraciet structuurlak (VS716)	
ART-044427	black textured paint zwart structuurlak (VS905)			
13		Post click profile round Staander klikprofiel rond		
		ART-024204	mill finish onbewerkt	5 m ¹
		ART-024205	white wit	
		ART-024207	anthracite textured paint antraciet structuurlak (VS716)	
ART-044426	black textured paint zwart structuurlak (VS905)			

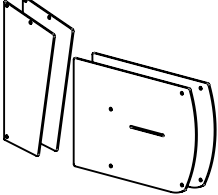
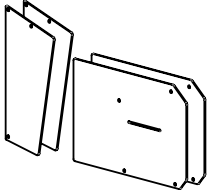
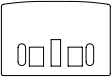
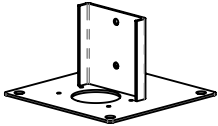
Parts list

Onderdelenlijst

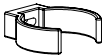
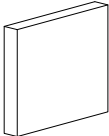
Part Onderdeel	Part No. Art.nr	Description Omschrijving	Length in m' Unit
PARTS ONDERDELEN			
14a 	ART-023428	Side plates round Eindkappen rond - SET mill finish onbewerkt	
	ART-023429	white wit	
	ART-023431	anthracite textured paint antraciet structuurlak (VS716)	
	ART-044409	black textured paint zwart structuurlak (VS905)	
14b 	ART-023432	Side plates straight Eindkappen recht - SET mill finish onbewerkt	
	ART-023433	white wit	
	ART-023435	anthracite textured paint antraciet structuurlak (VS716)	
	ART-044408	black textured paint zwart structuurlak (VS905)	
15 	ART-023438	End cap beam Eindplaat ligger	
17 	ART-023443	Foot Montagevoet	
18 	ART-023334	Drain Afvoerbuis - Ø50 mm	
19 	ART-023336	Leaf guard Bladvanger - Ø50 mm	
20 	ART-023448	Drop outlet Uitloop PVC (tule) - Ø50 mm	
21 	ART-023449	Nut for drop outlet Moer voor Uitloop - Ø50 mm	
22 	ART-023335	Pipe bracket Klembeugel - Ø50 mm	
23 	ART-036319	Gutter reinforcement Versterking goot - 90x10 mm Hotrolled steel galvanized WGW Stafstaal verzinkt	5 m ¹
	ART-024089	Hotrolled steel galvanized WGW Stafstaal verzinkt	6 m ¹

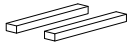
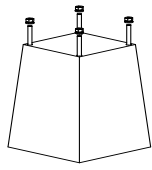
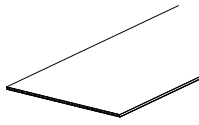
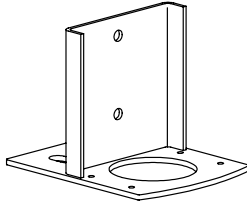
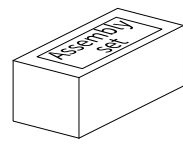
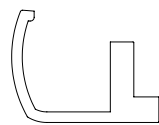
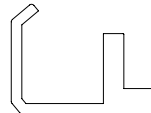

Parts list

Onderdelenlijst

Part Onderdeel	Part No. Art.nr	Description Omschrijving	Length in m ¹ Unit
24		Set for reinforcement gutter Opvulstukken voor versterking goot - 10x5 mm set of 2 set van 2 stuks	
ART-023446			
25		Concrete block Betonpoer - 23x23x25 cm	
ART-023345			
26		Polycarbonate sheet Polycarbonaat plaat - 16 mm	
ART-023890	clear helder - 600 x 098	6 m ¹	
ART-023891	clear helder - 700 x 098	7 m ¹	
ART-023892	clear helder - 700 x 120	7 m ¹	
ART-023893	opal opaal - 600 x 098	6 m ¹	
ART-023894	opal opaal - 700 x 098	7 m ¹	
ART-023895	opal opaal - 700 x 120	7 m ¹	
ART-039493	reflective zonwerend - 700 x 098	7 m ¹	
ART-023899	2-room clear 2-kamer helder - 700 x 098	7 m ¹	
VARIOUS OVERIGEN			
	Foot small (inner size post - showroom) Montagevoet vlak (binnenmaat staander - showroom) steel staal		
ART-023444			
	Assembly set foot small Bevestigingsset montagevoet vlak		
ART-023447			
	EPDM waterproof seal for side cover of the gutter round EPDM waterdichte foamafdichting voor zijkap goot rond white wit black zwart		
ART-023426			
ART-023427			
	EPDM waterproof seal for side cover of the gutter straight EPDM waterdichte foamafdichting voor zijkap goot recht white wit black zwart		
ART-023424			
ART-023425			

Parts list

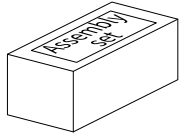
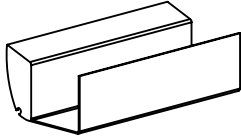
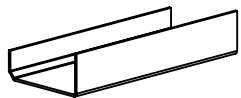
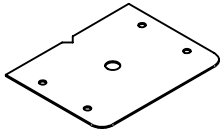
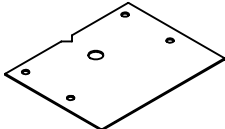
Onderdelenlijst

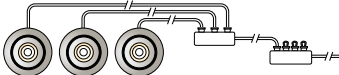
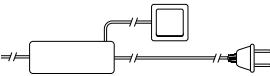
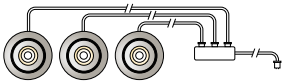
Part Onderdeel	Part No. Art.nr	Description Omschrijving	Length in m' Unit
	ART-023423	Assembly set Bevestigingsset	
	ART-023436	Coupling piece gutter round Koppelstuk goot rond > 7000 mm (max. 14000 mm)	
	ART-023437	Coupling piece gutter straight Koppelstuk goot recht > 7000 mm (max. 14000 mm)	
	ART-023419	Drilling guide gutter round Boormal goot rond	
	ART-023420	Drilling guide gutter straight Boormal goot recht	
	ART-023380	Antidust closed tape Gesloten tape - 16 mm	
	ART-023381	Antidust filtertape Filtertape - 16 mm	
 	ART-023365	Lighting Set 1: 3x LED 2,5 Watt spots incl. driver (dimnable), puls switch and wires. Driver is suitable to control max. 12 LED spots. Verlichtingset 1: 3x LED Watt spots incl. driver (dimbaar), pulsschakelaar en bekabeling. Driver is geschikt om max. 12 stuks LED spots te sturen.	
	ART-023367	Lighting Set 2: 3x LED 2,5 Watt spots incl. wires (no driver) (=complement to Set 2) Verlichtingset 2: 3x LED 2,5 Watt spots incl. bekabeling (zonder driver) (=aanvulling op Set 2)	

Additional technical information

Aanvullende technische informatie

Processing the polycarbonate sheets Verwerking polycarbonaat platen

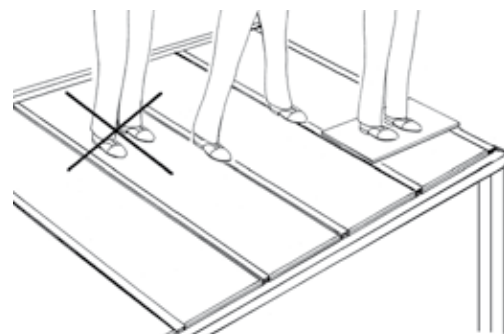
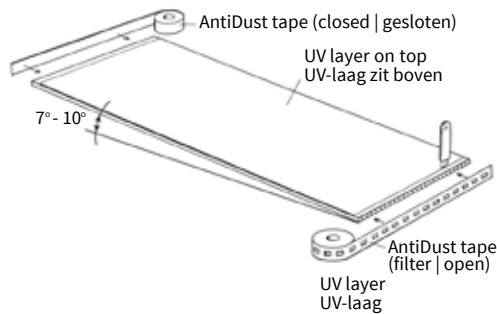
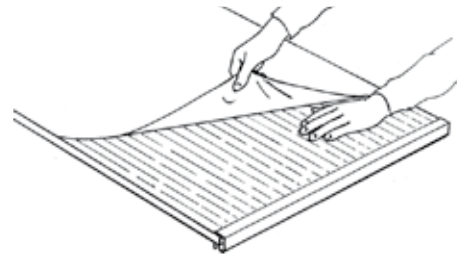
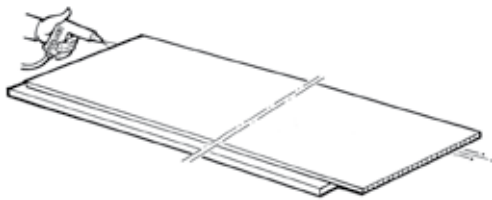
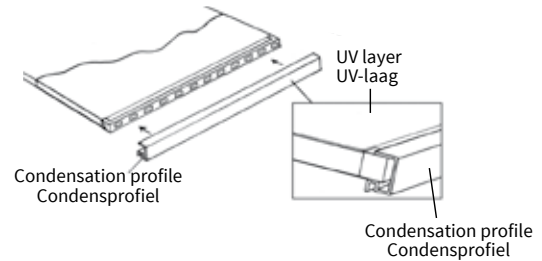
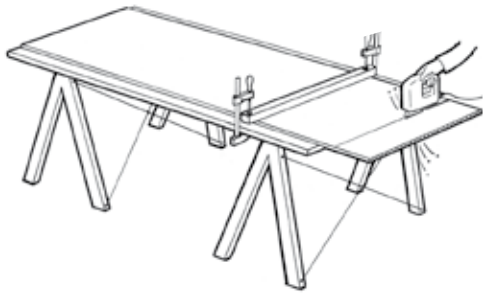

Warning! In the polycarbonate condensation may occur. This is not preventable and is no reason for replacement under warranty.

Let op! In het polycarbonaat kan condensatie optreden. Dit kan niet worden voorkomen en is geen reden voor vervanging onder garantie.

BOLBYR

BOLBYR®

Bolbyr B.V. - Magazijnweg 27-29 - 5683 CV Best - Nederland (Netherlands)
T +31 (0)88-9876543 - sales@bolbyr.com - www.bolbyr.com